



OSR STATIONARY BULK CONVEYORS

- ***Rugged heavy duty design with classic style outside flanges make this conveyor the ideal choice for conveying anything from bulk seed and grain to ear corn. With its single trough roller design and its ability to clearspan up to 32', it is able to handle longer lengths and heavy loading with less supports, while still maintaining its capacity.***
- ***12", 18", 24", 30", or 36" belt widths. Standard belt Speed 200 fpm.***
- ***Right angle, shaft mounted, and chain final drives available.***
- ***208-230/460 volt 3 phase and 230 volt single phase TEFC motors available.***
- ***Formed mild steel conveyor frame with 40 degree troughing angles.***
- ***White alkyd enamel finish. Powder coat finishes and custom colors available upon request.***
- ***Vulcanized rough top lagging on head pulley.***
- ***Every unit comes standard with all moving parts guarded (Pulleys, Shafts, Bearings, Take-up, and Drive). These items are not treated as options.***

O'MARA EQUIPMENT COMPANY

***Resourceful and Productive Solutions for Seed, Grain,
Edibles, and Feed Equipment***

OSR STATIONARY BULK CONVEYORS

OSR STANDARD FEATURES:

■ **CONVEYOR FRAMES:** Head and take-up sections are fabricated from 10 gauge mild steel, intermediate sections are 14 gauge mild steel. Welded construction with a 40 degree troughing angle and 2" dia. single trough rollers placed 12" o.c. Flanged style connections with grade 5, zinc plated hardware.

■ **BELT WIDTHS:** 12", 18", 24", 30", or 36" wide.

■ **BELTING TYPES:** Minimum PVC 120# friction back belting. Smooth top, crescent/scoop top, and cleated belts are available depending on the application. Alligator 125 Redi-Set stainless steel lacing. Standard belt speed is 200 fpm. Other belt speeds are available upon request to meet desired capacity requirements.

■ **POWER/MOTORS:** 208-230/460 3 phase and 230 volt single phase TEFC motors. Explosion proof available upon request.

■ **DRIVES:** Dodge TA and TiGear, Boston Gear, and Grove gear reduction drives available. Shaft mounted, right angle shaft mounted, and right angle/chain final configurations are available.

■ **COMPONENTS:** Crowned and vulcanized rough top lagged head pulleys and crowned take-up and idler pulleys. Standard sizes are 6", 8", and 12" dia. Snub pulleys are 4" dia. Self aligning, normal duty, eccentric lock ball bearings. Screw style take-ups.

■ **GUARDING:** Every units has all of its moving parts guarded, including: Pulleys, Bearings, Shafts, Take-up, and Drive as a standard feature, not as an option.

AVAILABLE OPTIONS:

■ **TOP COVERS:** 14 gauge formed galvanized, weather tight top covers.

■ **BOTTOM COVERS:** 14 gauge formed mild steel, hinged bottom covers. Screwed-on expanded metal covers also available.

■ **BELT SKIRTING:** 1/4" skirt board rubber. Skirted inlet loaders or skirted to any length as required.

■ **DISCHARGE CHUTE:** 12 gauge mild steel discharge chute with full width belt wiper. Different styles available including lined.

■ **GUARDING:** Different guarding packages available to suite your safety requirements.

■ **VFD DRIVE:** Inveter duty motors and vfd drive allows you to "dial in" your belt speed as needed.

■ **SECTIONS:** 12 gauge sections in lieu of 14 gauge. Available in lengths from 1' to 12'.

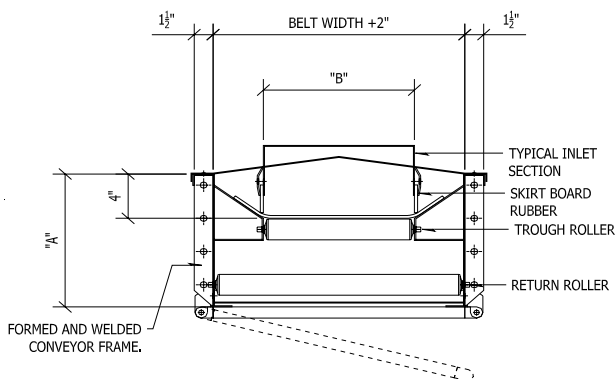

Standard Conveyor Cross-Section.

Shown with top cover and hinged bottom cover.

BELT WIDTH	DIM "A" 6" PULLEYS	DIM "A" 8" PULLEYS	DIM "A" 12" PULLEYS	DIM "B"
12"	10"	12"	16"	6"
18"	10"	12"	16"	12"
24"	10"	12"	16"	18"
30"	10"	12"	16"	24"
36"	10"	12"	16"	30"

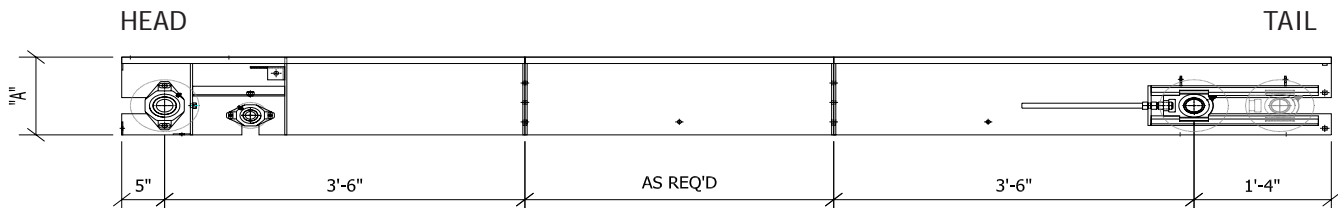

Shown less motor and drive for clarity.

Distributed by:
O'MARA AG SERVICES, INC.
 PO Box 42007
 Urbandale, ia 50323
 PH/FX: 515/223-5391
 Email: info@omara-ag.com
 Website: www.omara-ag.com